

### Features of the power supply unit:

- The output voltage range 44-57VDC
- Can be powered from a PoE switch or external power supply
- The PoE IN input compatible with the IEEE 802.3af/at standard
- The PoE OUT1/PoE OUT2 output are not compliant with the IEEE 802.3af/at standard
- Increases Ethernet and PoE power range by 100 meters
- designed for 10Mbit/s and 100Mbit/s network
- LED optical signalization
- protections:
  - surge protection (PoE input)
  - OLP overload protection
  - SCP short circuit protection
- warranty – 2 year from the production date

## 1. Technical description.

### 1.1. General description.

The **EXT-POE4** extender is a device designed to increase the PoE and Ethernet range by additional 100 meters using UTP Cat. 5 cable. The Extender can be powered using a PoE switch or another PoE-compliant device (PoE IN input) or an external 44-57VDC power supply unit (DC IN input). The power source is selected using the *Power Source* jumper (see Fig. 1). The output voltage and data are available at the PoE OUT1 and OUT2 outputs designed for connecting cameras or other IP devices using PoE power supply. The maximum load current is 0,4A (0,3A/port). The PoE OUT1 and PoE OUT2 ports are supplied over 4/5 (+) and 7/8 (-) pairs, which, according to the Ethernet standard, are not used for data transmission (data transmission uses 1/2 and 3/6 twisted pairs).

**This device cannot be used on Gigabit Ethernet networks, where all twisted pairs are involved in data transmission.**

### 1.2. Technical parameters.

<b>Supply voltage</b>	802.3af/at / 44 ÷ 57VDC
<b>Current consumption by PSU systems</b>	<30mA
<b>Module power</b>	20W max.
<b>Output voltage</b>	applying power
<b>Output current</b>	0,3A/ports ( $\Sigma=0,4A$ max.)
<b>The PoE IN input power supply pairs</b>	4/5 (+) 7/8 (-)
<b>The PoE OUT1/2 output power supply pairs</b>	4/5 (+) 7/8 (-)
<b>Overload protection OLP</b> <b>Short circuit protection SCP</b>	2x PTC 0,5A, polymer fuse
<b>LED operation indication</b>	Yellow <b>LAN</b> LED - indicating the LAN connection status The <b>PoE</b> LED (green) indicating the supply voltage
<b>Operation conditions</b>	II environmental class, -10°C÷40°C
<b>Dimensions (LxWxH)</b>	81 x 77 x 26 [mm]
<b>Mounting</b>	mounting screws x2 (holes Ø 6mm)
<b>Connectors:</b> - DC IN power supply input - IN/OUT PoE	Ø0,5÷2,1 (AWG 24-12) 0,5÷1,5mm <sup>2</sup> RJ45 8P8C
<b>Net/gross weight</b>	0,11kg / 0,15kg
<b>Storage temperature</b>	-20°C...+60°C
<b>Declarations, warranty</b>	CE, 2 years from the production date

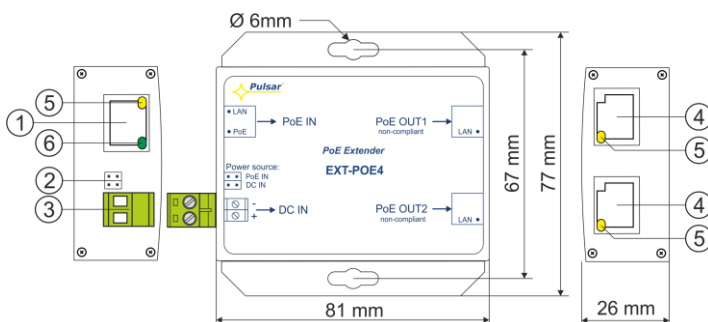



Fig.1. A schematic drawing of the device.

Table 2. Description of components and connectors.

Element no. [fig. 1]	Description
[1]	The PoE IN-input port
[2]	Power source - power supply selection jumper:  PoE IN (factory settings) DC IN
[3]	DC IN - Power supply input
[4]	PoE OUT 1/2 - Output ports
[5]	LED LAN (yellow)
[6]	LED PoE (green)

\* If there is no jumper, the device is not powered.

Connection schemes:

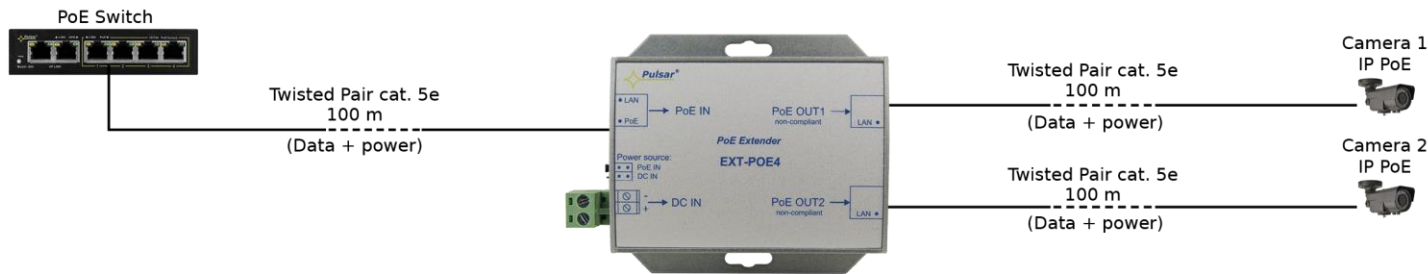

Connection of two IP PoE cameras and extension of the range for another 100m

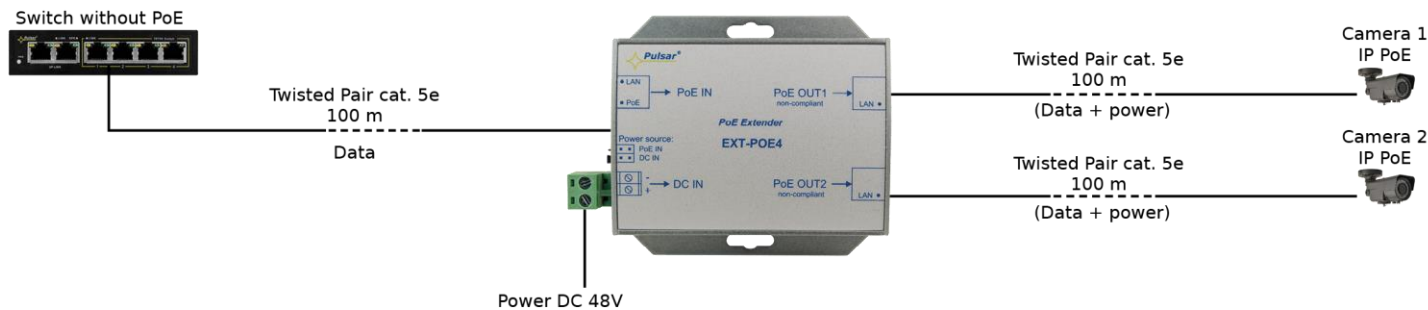

Use of the locally powered EXT-PoE4 extender  
Connection of two IP PoE cameras and extension of the range for another 100m

2. Installation.

2.1. Requirements.

The extender should be mounted by a qualified installer, holding relevant permits and licenses (applicable and required for a given country) for low-voltage installations. The device shall be mounted in confined spaces (in accordance with the 2nd environmental class) with normal air humidity (RH=90% max. without condensation) and the temperature from -10°C to +40°C

The device is designed for a 10Mbit/s or 100Mbit/s Ethernet network (the so-called Fast Ethernet). **However, it cannot be used in 1Gbit/s networks (the so-called Gigabit Ethernet).** The minimum category cable recommended to connect the extender and the network device is UTP Cat. 5 cable.

2.2. Installation procedure.

Connect the network cables (Ethernet) to the RJ45 connectors marked PoE IN and PoE OUT. Connect the RJ45 cable from the Ethernet switch to the PoE IN jack. When using a switch non compliant with the PoE standard, connect an external power source to the DC IN jack. Then, use the jumper to choose the power source. Connect devices, such as IP cameras, to the PoE OUT 1/2 outputs e.g. IP cameras.

3. Maintenance.

Any and all maintenance operations may be performed following the disconnection of the power supply from the power network. The power supply does not require any specific maintenance procedures, however, in the case of significant level of dust, it should be cleaned with compressed air.



WEEE MARK

According to the EU WEE Directive – It is required not to dispose of electric or electronic waste as unsorted municipal waste and to collect such WEEE separately.

Pulsar sp. j.

Siedlec 150, 32-744 Łapczyca, Poland  
Tel. (+48) 14-610-19-40, Fax. (+48) 14-610-19-50  
e-mail: [biuro@pulsar.pl](mailto:biuro@pulsar.pl), [sales@pulsar.pl](mailto:sales@pulsar.pl)  
http:// [www.pulsar.pl](http://www.pulsar.pl), [www.zasilacze.pl](http://www.zasilacze.pl)